

THESE TABLES APPLY TO JRC PART NUMBERS:

100-60859C25 REV 7
100-80859C25 REV 9

Base Angle: 2 x 1 1/2 x 1/4

Headblock Load Rating Table Instructions

NOTE: There are individual tables for each size and orientation of head block

- Review the LIMITS OF USE section shown on the right hand side of this document. If your project does not meet the LIMITS OF USE, please contact J R Clancy for further information.
- Review the project for the exact requirements of your specific head block. You will need to know the following information prior to using the head block load rating tables:
 - Orientation of block (upright or underhung) and for underhung, the attachment method.
 - Size of the block (sheave diameter at: 8", 12", or 16")
 - The clear distance between the supporting head steel flanges (NOT the beam centerline distance).
 - The distance from the onstage side of the offstage beam flange to the offstage handline.
- Once you know the above information find the tables that match the size and orientation of the headblock you need.
- Once you have located the tables for your particular block, on TABLE 1, go to the leftmost column on the table labeled "Clear Distance Between Flanges" or "Center - Center Weld Distance". Read down until you find the distance specific to your project.
- Next find the "Distance Between Offstage Beam Flange and Handline (Dimension X)" across the top row of the spreadsheet.
- Where your selected Row and Column intersect will be the Gross Load Capacity (in lbs.) of your headblock.
- Next find the cable diameter and sheave type in TABLE 2 below. Calculate the Tread Pressure Limited Capacity by multiplying the maximum individual line load x the number of lift lines.
- Your final maximum RWL for your head block will be the lesser of:
 - the Gross RWL from the Table, OR
 - the Tread Pressure Limited Capacity.

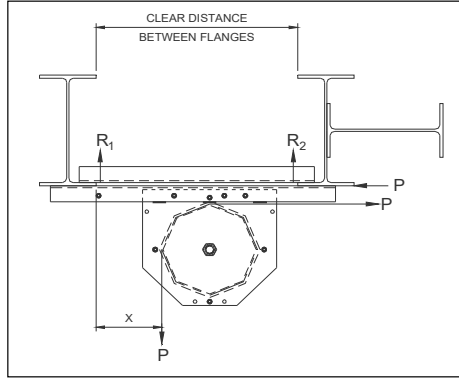

Head Blocks - LIMITS OF USE

NOTE: RWL (Recommended Working Load) is a function of mounting conditions and is only valid when the following criteria are met:

- All lift lines wrap 90° around the sheave, all hand lines wrap 180° around the sheave.
- All headblocks mount on two beams, with the shaft between the beam centerlines.
- All cable fleet angles are less than 1.5°.
- For Underhung Headblocks, they shall be attached to structural steel in one of the following three methods:
 - beam clip angles, min. two 2" x 1 1/4" x 1/4" angles, back to back bolted with two 1/2" gr 5 bolts.
 - formed clips with two 1/2" gr 5 bolts, from one of the following JRC part #'s :
 - 070-38650, 070-38675, 070-386100
 - 070-38850, 070-38875, 070-388100
 - welded directly to the beam, min. four 1/4" fillet welds at 1.5" in length ea.
- For Upright Headblocks they shall be attached to structural steel by either b), or c) above.
- The onstage connection to structure must have the bolt bear directly against the mounting steel in shear.
- CONTACT J R CLANCY FOR OTHER MOUNTING CONDITIONS.

NOTE: The above values are based on block capacity only and do not reflect the capacity of the cable you use. Consult your wire rope manufacturer for the RWL for your particular cable.

TABLE 1 - HEAD BLOCK GROSS LOAD CAPACITY (in lbs.) - 8" Single Purchase Underhung Head Block with Beam Angles

Clear Distance Between Flanges	Distance Between Offstage Beam Flange and Offstage Handline (Dimension "X")																	
	-4	-3	-2	-1	0	1	2	3	4	5	6	7	8	9	10	11	12	13
10	1517	2303	2737	2906	2906	2906	2906	2906	2906	2446	2078							
11	1369	1967	2838	2906	2906	2906	2906	2906	2906	2378	1979	1816						
12	1268	1757	2596	2906	2906	2906	2906	2906	2906	2325	1905	1712	1645					
13	1194	1613	2300	2906	2906	2906	2906	2906	2906	2283	1847	1634	1539	1526				
14	1138	1509	2097	2906	2906	2906	2906	2906	2906	2248	1801	1573	1458	1417	1438			
15	1094	1430	1950	2823	2906	2906	2906	2906	2906	2219	1763	1525	1396	1336	1328	1370		
16	1059	1367	1838	2612	2906	2906	2906	2906	2906	2195	1732	1485	1346	1272	1245	1259	1317	
17	1029	1317	1750	2451	2906	2906	2906	2906	2906	2174	1705	1452	1306	1221	1180	1175	1204	1273
18	1005	1276	1680	2325	2906	2906	2906	2906	2906	2156	1682	1424	1272	1179	1128	1109	1119	1159
19	984	1241	1621	2223	2906	2906	2906	2906	2906	2140	1662	1401	1243	1145	1086	1057	1053	1074
20	966	1212	1572	2139	2906	2906	2906	2906	2906	2126	1645	1380	1218	1115	1051	1014	1001	1008
21	951	1187	1531	2069	2906	2906	2906	2906	2906	2114	1630	1362	1197	1090	1021	979	958	955
22	937	1165	1495	2009	2897	2906	2906	2906	2906	2102	1616	1346	1178	1068	996	949	922	911
23	925	1145	1464	1958	2807	2906	2906	2906	2906	2092	1604	1331	1162	1049	974	923	891	875
24	914	1128	1437	1913	2729	2906	2906	2906	2906	2083	1593	1319	1147	1033	954	901	865	845

Indicates dimension recommended in JRC Design Guide

TABLE 2 - MAXIMUM LINE LOADS			
8.5" Sheave Line Load limited by Tread Pressure			
Cable Diameter	Cast	Steel	Nylon
1/4"	500	1000	3500

NOTE: The above values are based on block capacity only and do not reflect the capacity of the cable you use. Consult your wire rope manufacturer for the RWL for your particular cable.

[Index](#)

THESE TABLES APPLY TO JRC PART NUMBERS:

100-60859C25 REV 7
100-80859C25 REV 9

Base Angle: 2 x 1 1/2 x 1/4

Headblock Load Rating Table Instructions

NOTE: There are individual tables for each size and orientation of head block

- Review the LIMITS OF USE section shown on the right hand side of this document. If your project does not meet the LIMITS OF USE, please contact J R Clancy for further information.
- Review the project for the exact requirements of your specific head block. You will need to know the following information prior to using the head block load rating tables:
 - Orientation of block (upright or underhung) and for underhung, the attachment method.
 - Size of the block (sheave diameter at: 8", 12", or 16")
 - The clear distance between the supporting head steel flanges (NOT the beam centerline distance).
 - The distance from the onstage side of the offstage beam flange to the offstage handline.
- Once you know the above information find the tables that match the size and orientation of the headblock you need.
- Once you have located the tables for your particular block, on TABLE 1, go to the leftmost column on the table labeled "Clear Distance Between Flanges" or "Center - Center Weld Distance". Read down until you find the distance specific to your project.
- Next find the "Distance Between Offstage Beam Flange and Handline (Dimension X)" across the top row of the spreadsheet.
- Where your selected Row and Column intersect will be the Gross Load Capacity (in lbs.) of your headblock.
- Next find the cable diameter and sheave type in TABLE 2 below. Calculate the Tread Pressure Limited Capacity by multiplying the maximum individual line load x the number of lift lines.
- Your final maximum RWL for your head block will be the lesser of:
 - the Gross RWL from the Table, OR
 - the Tread Pressure Limited Capacity.

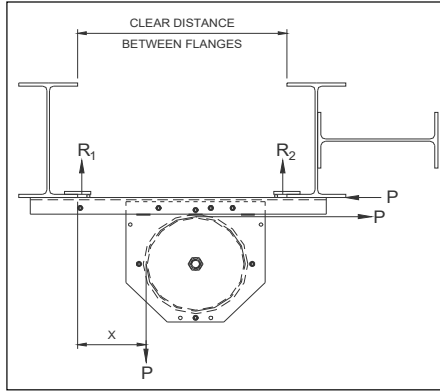

Head Blocks - LIMITS OF USE

NOTE: RWL (Recommended Working Load) is a function of mounting conditions and is only valid when the following criteria are met:

- All lift lines wrap 90° around the sheave, all hand lines wrap 180° around the sheave.
- All headblocks mount on two beams, with the shaft between the beam centerlines.
- All cable fleet angles are less than 1.5°.
- For Underhung Headblocks, they shall be attached to structural steel in one of the following three methods:
 - beam clip angles, min. two 2" x 1 1/4" x 1/4" angles, back to back bolted with two 1/2" gr 5 bolts.
 - formed clips with two 1/2" gr 5 bolts, from one of the following JRC part #'s :
 - 070-38650, 070-38675, 070-386100
 - 070-38850, 070-38875, 070-388100
 - welded directly to the beam, min. four 1/4" fillet welds at 1.5" in length ea.
- For Upright Headblocks they shall be attached to structural steel by either b), or c) above.
- The onstage connection to structure must have the bolt bear directly against the mounting steel in shear.
- CONTACT J R CLANCY FOR OTHER MOUNTING CONDITIONS.

TABLE 1 - HEAD BLOCK GROSS LOAD CAPACITY (in lbs.) - 8" Single Purchase Underhung Head Block with Beam Clips

Clear Distance Between Flanges	Distance Between Offstage Beam Flange and Offstage Handline (Dimension "X")																	
	-4	-3	-2	-1	0	1	2	3	4	5	6	7	8	9	10	11	12	13
10	498	532	570	613	665	725	797	886	997	1139	1329							
11	521	554	591	633	682	738	805	886	984	1108	1266	1477						
12	541	573	609	650	696	750	812	886	975	1083	1218	1392	1624					
13	560	591	625	665	709	759	818	886	967	1063	1181	1329	1519	1526				
14	576	606	640	678	720	768	823	886	960	1047	1152	1280	1440	1417	1438			
15	591	620	653	689	730	775	827	886	954	1034	1128	1240	1378	1336	1328	1370		
16	604	633	665	699	738	782	831	886	949	1022	1108	1208	1329	1272	1245	1259	1317	
17	616	644	675	709	746	788	834	886	945	1013	1090	1181	1289	1221	1180	1175	1204	1273
18	628	655	685	717	753	793	837	886	941	1004	1076	1159	1255	1179	1128	1109	1119	1159
19	638	665	693	725	759	797	839	886	938	997	1063	1139	1227	1145	1086	1057	1053	1074
20	647	673	701	732	765	802	842	886	935	990	1052	1122	1202	1115	1051	1014	1001	1008
21	656	682	709	738	770	805	844	886	933	984	1042	1108	1181	1090	1021	979	958	955
22	665	689	716	744	775	809	846	886	930	979	1034	1094	1163	1068	996	949	922	911
23	672	696	722	750	780	812	847	886	928	975	1026	1083	1147	1049	974	923	891	875
24	679	703	728	755	784	815	849	886	926	970	1019	1073	1132	1033	954	901	865	845

Indicates dimension recommended in JRC Design Guide

TABLE 2 - MAXIMUM LINE LOADS			
8.5" Sheave Line Load limited by Tread Pressure			
Cable Diameter	Cast	Steel	Nylon
1/4"	500	1000	3500

NOTE: The above values are based on block capacity only and do not reflect the capacity of the cable you use. Consult your wire rope manufacturer for the RWL for your particular cable.

[Index](#)

THESE TABLES APPLY TO JRC PART NUMBERS:

100-60859C25 REV 7
100-80859C25 REV 9

Base Angle: 2 x 1 1/2 x 1/4

Headblock Load Rating Table Instructions

NOTE: There are individual tables for each size and orientation of head block

- Review the LIMITS OF USE section shown on the right hand side of this document. If your project does not meet the LIMITS OF USE, please contact J R Clancy for further information.
- Review the project for the exact requirements of your specific head block. You will need to know the following information prior to using the head block load rating tables:
 - Orientation of block (upright or underhung) and for underhung, the attachment method.
 - Size of the block (sheave diameter at: 8", 12", or 16")
 - The clear distance between the supporting head steel flanges (NOT the beam centerline distance).
 - The distance from the onstage side of the offstage beam flange to the offstage handline.
- Once you know the above information find the tables that match the size and orientation of the headblock you need.
- Once you have located the tables for your particular block, on TABLE 1, go to the leftmost column on the table labeled "Clear Distance Between Flanges" or "Center - Center Weld Distance". Read down until you find the distance specific to your project.
- Next find the "Distance Between Offstage Beam Flange and Handline (Dimension X)" across the top row of the spreadsheet.
- Where your selected Row and Column intersect will be the Gross Load Capacity (in lbs.) of your headblock.
- Next find the cable diameter and sheave type in TABLE 2 below. Calculate the Tread Pressure Limited Capacity by multiplying the maximum individual line load x the number of lift lines.
- Your final maximum RWL for your head block will be the lesser of:
 - the Gross RWL from the Table, OR
 - the Tread Pressure Limited Capacity.

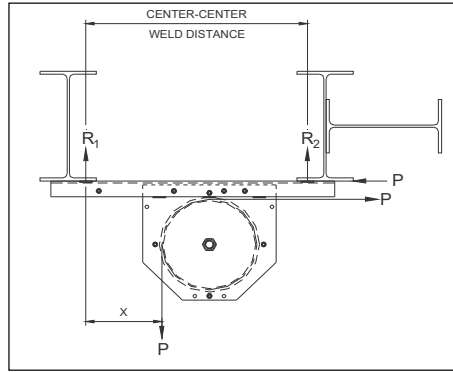

Head Blocks - LIMITS OF USE

NOTE: RWL (Recommended Working Load) is a function of mounting conditions and is only valid when the following criteria are met:

- All lift lines wrap 90° around the sheave, all hand lines wrap 180° around the sheave.
- All headblocks mount on two beams, with the shaft between the beam centerlines.
- All cable fleet angles are less than 1.5°.
- For Underhung Headblocks, they shall be attached to structural steel in one of the following three methods:
 - beam clip angles, min. two 2" x 1 1/4" x 1/4" angles, back to back bolted with two 1/2" gr 5 bolts..
 - formed clips with two 1/2" gr 5 bolts, from one of the following JRC part #'s :
 - 070-38650, 070-38675, 070-386100
 - 070-38850, 070-38875, 070-388100
 - welded directly to the beam, min. four 1/4" fillet welds at 1.5" in length ea.
- For Upright Headblocks they shall be attached to structural steel by either b), or c) above.
- The onstage connection to structure must have the bolt bear directly against the mounting steel in shear.
- CONTACT J R CLANCY FOR OTHER MOUNTING CONDITIONS.

NOTE: The above values are based on block capacity only and do not reflect the capacity of the cable you use. Consult your wire rope manufacturer for the RWL for your particular cable.

TABLE 1 - HEAD BLOCK GROSS LOAD CAPACITY (in lbs.) - 8" Single Purchase Underhung Head Block with Welds

Center - Center Weld Distance	Distance Between Offstage Weld Centerline and Offstage Handline (Dimension "X")																	
	-4	-3	-2	-1	0	1	2	3	4	5	6	7	8	9	10	11	12	13
10	1627	2426	2906	2906	2906	2906	2906	2906	2751	2138	1876							
11	1482	2115	2906	2906	2906	2906	2906	2906	2708	2075	1789	1666						
12	1380	1911	2820	2906	2906	2906	2906	2906	2673	2025	1722	1575	1523					
13	1304	1767	2531	2906	2906	2906	2906	2906	2644	1985	1669	1505	1430	1420				
14	1245	1659	2326	2906	2906	2906	2906	2906	2619	1952	1626	1450	1359	1325	1342			
15	1198	1576	2173	2906	2906	2906	2906	2906	2598	1924	1591	1406	1303	1253	1246	1282		
16	1160	1510	2055	2906	2906	2906	2906	2906	2580	1900	1561	1369	1257	1196	1173	1185	1233	
17	1128	1456	1961	2807	2906	2906	2906	2906	2565	1880	1536	1338	1219	1150	1111	1111	1135	1193
18	1101	1412	1885	2670	2906	2906	2906	2906	2551	1862	1514	1312	1188	1111	1068	1052	1060	1094
19	1078	1374	1821	2558	2906	2906	2906	2906	2539	1846	1495	1290	1161	1079	1030	1005	1002	1019
20	1058	1341	1767	2465	2906	2906	2906	2906	2528	1832	1478	1270	1138	1052	997	966	954	960
21	1041	1313	1721	2386	2906	2906	2906	2906	2518	1820	1464	1253	1118	1028	969	933	914	912
22	1026	1289	1682	2319	2906	2906	2906	2906	2510	1809	1450	1237	1100	1008	946	905	881	872
23	1012	1267	1647	2261	2906	2906	2906	2906	2502	1799	1439	1224	1084	990	925	881	853	839
24	1000	1248	1616	2210	2906	2906	2906	2906	2494	1790	1428	1211	1070	974	907	860	829	811

Indicates dimension recommended in JRC Design Guide

TABLE 2 - MAXIMUM LINE LOADS			
8.5" Sheave Line Load limited by Tread Pressure			
Cable Diameter	Cast	Steel	Nylon
1/4"	500	1000	3500

NOTE: The above values are based on block capacity only and do not reflect the capacity of the cable you use. Consult your wire rope manufacturer for the RWL for your particular cable.

[Index](#)